

## B-Three

Industrial power, ideal for water heating boilers, warm air generators, baking ovens and other industrial environments. Equipped with removable display unit. High quality materials for long term performances.

Output: **300 kW**



### Features:



#### ECOLOGICAL

##### Nature thanks

- Heating with neutral CO2 emissions
- Renewable energy which represents a safe investment for the future



#### COMFORT

##### Comfortable and safe

- Automatic combustion system.
- Automatic cleaning of the heating surfaces and of the burner
- Remote assistance and system monitoring available



#### COST-EFFECTIVE

##### Investment payback in the short term

- Operating costs reduced by up to 60% compared to diesel / gas systems
- High efficiency thanks to the most modern combustion technology
- Independent of trends in the market prices of fossil fuels
- Allows you to convert your system into a biomass system with only the replacement of the burner and therefore a far lower cost than buying a new boiler
- Quick return on investment

### Description

Burner for industrial heating. The compact dimensions make it easy to combine with different types of heating systems.

Designed with round combustion chamber, variable speed fan, internal auger for a more effective dosage, igniter and flame detection photocell.

For a more complete and reliable cleaning it is also possible to connect the device to an air compressor.

The burners is managed by a microprocessor control panel mounted on the appliance.



### Safety



**Safety thermostat** which interrupts the burner operation in case of temperature outside the combustion camera of the device higher than 70 ° C.



**External auger fan** protects against any extraordinary smoke returns.



**Security system** that locks and signals the system in lockout during any alarm situation



**The self-extinguishing** flexible hose avoids the thermal connection between the burner and the fuel storage



**Two-stage pellet loading** using an external auger that loads the fuel from the tank to the burner and an internal auger that conveys everything inside the combustion chamber.



**Automatic start** after power failure thanks to the memory of recent settings

#### Smart management of the heating system via smartphone and app.

All basic operating parameters and functions are remotely manageable, for constant control wherever you are.



### Technical details

Model	B-Three		
Thermal capacity	Max	kW	350
	Min	kW	35
Consumption	Max	Kg/h	70
	Min	Kg/h	7
Power supply	V/Hz	230/50	
Average consumption	W	150	
Start-up	W	170	
Noise Level	dB	60	
Weight	Kg	140	

\* consumption calculated with certified wood pellets UNI EN 14961-2 con P.C.I. 5,2 kW/kg

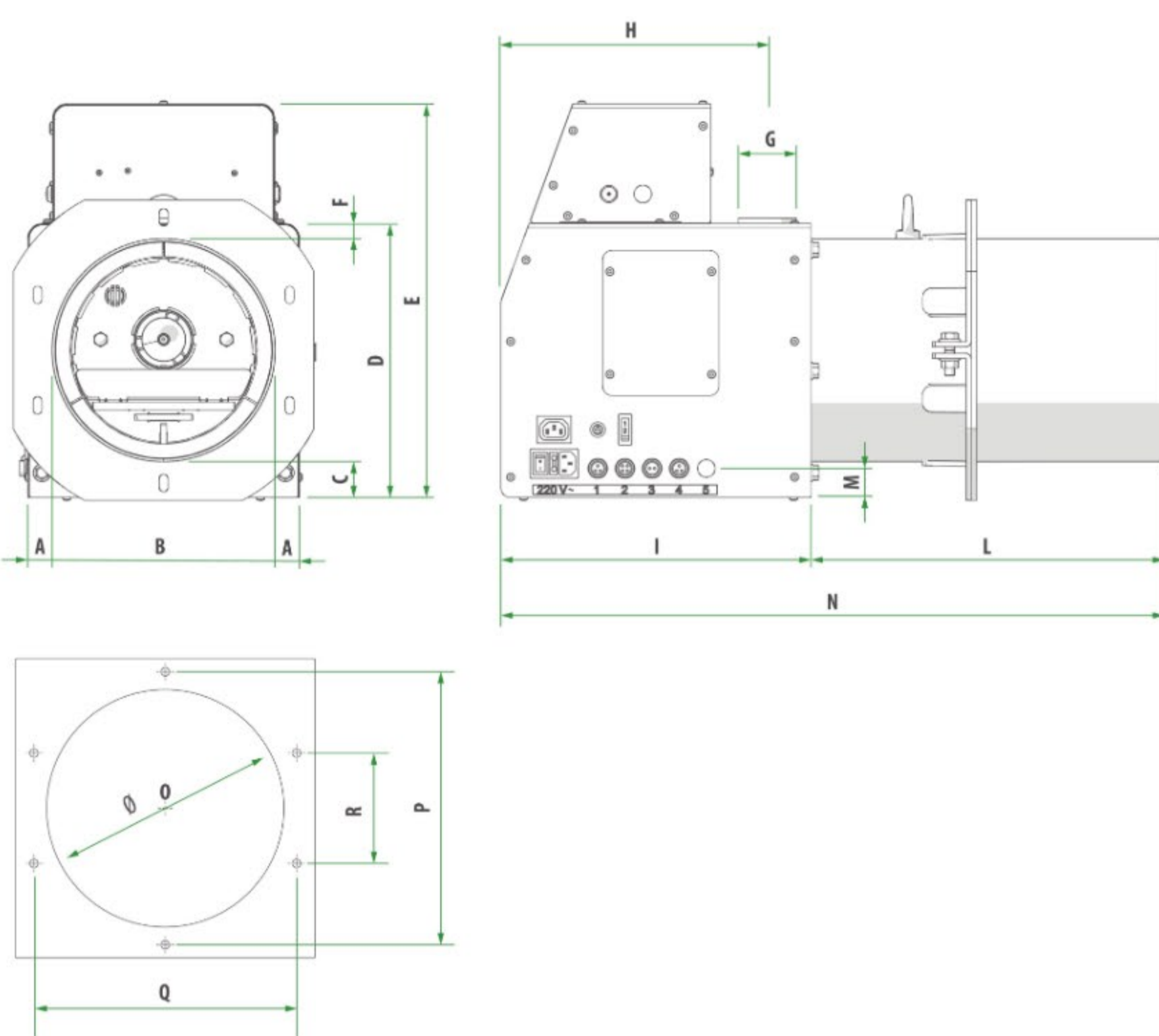

model	A	B	C	D	E	F	G	H	I	L	M	N	O	P	Q	R
	mm	mm	mm	mm	mm	Ø mm	mm	mm	mm	mm	mm	mm	Ø mm	mm	mm	mm
B-THREE	39	375	102	504	650	26,5	80	500	585	725	30	1310	382	450	420	190

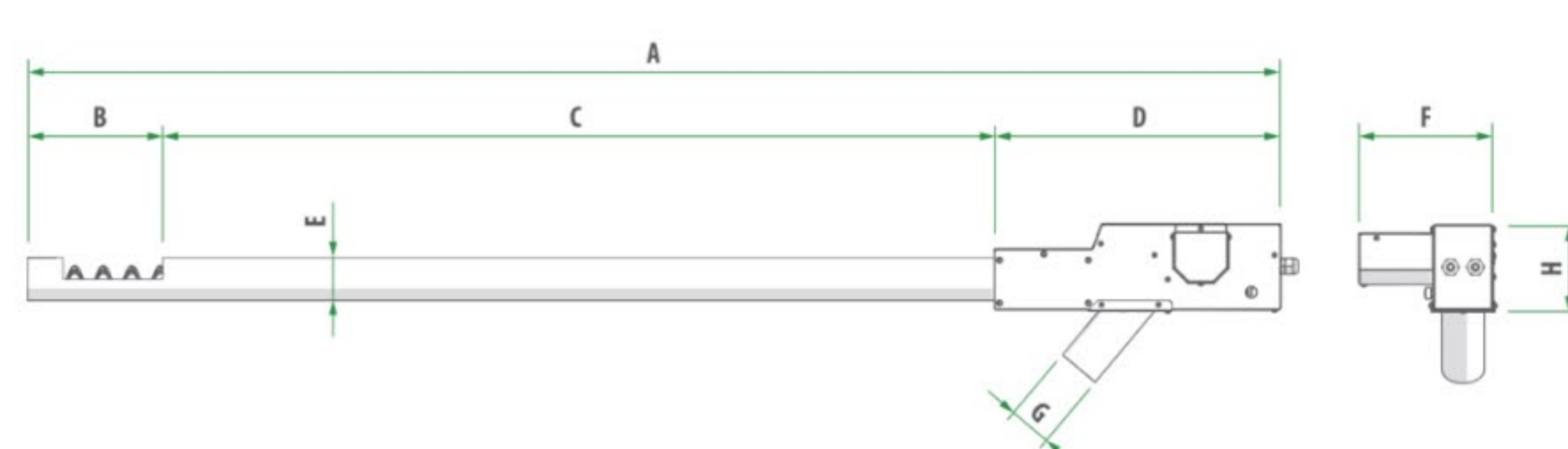

model	A	B	C	D	E	F	G	H	Weight
	mm	Ø mm	mm	mm	Ø mm	mm	Ø mm	mm	kg
B-Three	2338	140	1735	463	80	170	80	245	19